

**A REVISION OF THE GENUS *THASUS* (HEMIPTERA:
COREIDAE: COREINAE: NEMATOPODINI)**

HARRY BRAILOVSKY, CARL W. SCHAEFER,¹ ERNESTO BARRERA, AND
RICHARD J. PACKAUSKAS

Instituto de Biología, UNAM, Depto. de Zoología, Apdo. Postal No. 70-153,
México 04510, D.F., México, and
Department of Ecology and Evolutionary Biology, University of Connecticut,
Storrs, Connecticut 06269-3043

Abstract.— The neotropical coreid genus *Thasus* is revised. Of the eight species, five (*carchinus*, *luteolus*, *neocalifornicus*, *odonnellae*, and *rutilus*) are described as new. One of these, *T. neocalifornicus*, extends into the southwestern United States, where it has been misidentified as *T. gigas* or *acutangulus*. The species are keyed and analyzed cladistically, their distributions are discussed, and aspects of their morphology are illustrated.

In 1865, Stål removed from *Pachylis* LePeletier & Serville 1825 three species, *heteropus* (Latreille), *gigas* (Klug), and *acutangulus* (Stål), to a new genus, *Thasus*. Although he did not distinguish between the two genera in 1865, he had in effect done so earlier: in 1862, Stål separated the three species now in *Thasus* from those now in *Pachylis*, by the dilation of the hind tibia; this, in *Thasus*, occurs on both sides of the tibia and, in *Pachylis*, occurs only ventrally. In 1867, he used these characters in a key to separate these genera.

Since Stål's work, no systematic study has been made on *Thasus*, which is surprising for two reasons. First, the largest members of the genus are possibly the largest of the terrestrial Heteroptera and, in the suborder, are perhaps surpassed in size only by members of the Belostomatidae. Second, the species of the genus which extends into southwestern United States has never been satisfactorily identified (see below, and discussion in Froeschner, 1988): sometimes identified as *T. gigas*, and sometimes as *T. acutangulus*, the United States species is actually a new one, *T. neocalifornicus* sp.n. No other species of *Thasus* is known to occur in the U.S.

Here we redescribe the three species, describe five new ones, key all eight, and discuss briefly their cladistic relationships.

The following abbreviations are used in the text (see Heppner and Lamas, 1982): American Museum of Natural History, New York (AMNH); The Natural History Museum, London (BMNH); California Academy of Sciences, San Francisco (CAS); Ernst Heiss Collection (CEH); Carnegie Museum of Natural History, Pittsburgh (CMP); Cornell University Insect Collection (CU); Field Museum of Natural History, Chicago (FMNH); Florida State Collection of Arthropods, Gainesville (FSCA); Instituto de Biología de la Universidad Nacional Autónoma de México (IBUNAM); Los Angeles County Museum (LACM); Texas A&M University, College Station (TAMU); University of California, Berkeley (UCB); Universidad Central de Vene-

¹ To whom reprint requests should be addressed.

zuela, Escuela de Agronomía, Maracay (UCV); Universidad Central de Costa Rica, Museo de Entomología (UCCR); University of California, Riverside (UCR); United States National Museum, Smithsonian Institution, Washington, D.C. (USNM).

THASUS STÅL 1865:174

Pachylis acutangulus Stål 1859:439; designated by O'Shea (1980)

Redescription (modified from O'Shea [1980]): Body very large (δ : 29–43, ♀ : 28–40 mm long), broad, stout, somewhat depressed (Figs. 1–8). Head subquadrate; post-ocular tubercles forming smooth curve with eye; antennifers wide, close together; tylus projecting slightly anterior to antennifers. Antennae (Figs. 9–16) long, slender; segments 1, 2, 4 terete, 3 dilated, dilation symmetrical or asymmetrical; 1 relatively stout (especially apically), at least slightly clavate; 4 fusiform, slightly curved; antennal formula: $4 > 1 > 2 = 3$, except *T. gigas* ($1 = 4 > 2 = 3$) and *T. neocalifornicus* ($1 > 2 = 3 = 4$). Pronotum steeply declivent; callar region and collar clearly demarcated; lateral margins slightly nodulous or crenulate, anterior angles obtuse or rounded, humeral angles subobtuse to slightly produced into a spine; posthumeral, posterior margins smoothly sinuate; posterior angles rounded. Scutellum with broad transverse ridge anteriorly, posterior one-third slightly raised. Mesosternum without median longitudinal groove. Thoracic pleura with or without large pale hirsute areas. Metathoracic scent gland opening placed relatively laterally. Rostrum extending to or just beyond midmesosternum. Posterior trochanters of male armed with spine; all femora armed at least distally on ventral surface with spines; posterior femora incrassate, much more so in males (Figs. 17–19), dorsal surface smooth, ventral surface with spines; posterior tibiae of both sexes dilated equally ventrally and dorsally, male's ventral dilation with stout spine about two-thirds from base. Abdominal segments with spines (often large) at posterior corners. Spiracles in anterior third of sterna, closer to anterior than to lateral margins of abdominal segments. Male's genital capsule with sublateral projections on posterior margin; paramere relatively small and slender, with curved tip of "swan's neck" type (Figs. 20–22). Female's second valvula with heavily sclerotized tooth, this broad, flattened, bent inward, long or moderately long, tip variable; female connexivum 7 with spine (except *T. luteolus* and *acutangulus*); spermatheca (Figs. 23–29) oval, end away from duct tapered; spermathecal duct coiled distally and proximally, swollen proximal to distal coiling. *Diagnosis*: *Thasus* is a group of very large, stout, brown species, with dilated hind tibiae and dilated third antennal segments. The genus most likely to be confused with *Thasus*, is *Pachylis*, which is also large, stout, brown, and has the dilations.

In *Thasus* the metatibia is equally dilated on both sides of the midline (which can be recognized by a ridge [Figs. 17–19], which is the tibia itself). When viewed from the side, each border of the tibial ridge is equal. In *Pachylis* females, the metatibial dilation occurs only on one side of the ridge and, when viewed from the side, each border is highly asymmetrical; in males, the dilation occurs on both sides, but is also highly asymmetrical.

The dilation of the third antennal segment is unequal (asymmetrical) in *Pachylis*, and in four of the eight species of *Thasus* (*T. rutilus*, *heteropus*, *luteolus*, and *odonellae*); in the last three of these species, and in *Pachylis*, the dilation itself is relatively small.



Figs. 1-8. Dorsal views of *Thasus* spp. 1. *Thasus acutangulus* (Stål). 2. *T. carchinus* sp.n. 3. *T. gigas* (Klug). 4. *T. heteropus* (Latreille). 5. *T. luteolus* sp.n. 6. *T. neocalifornicus* sp.n. 7. *T. odonnellae* sp.n. (type). 8. *T. rutilus* sp.n.



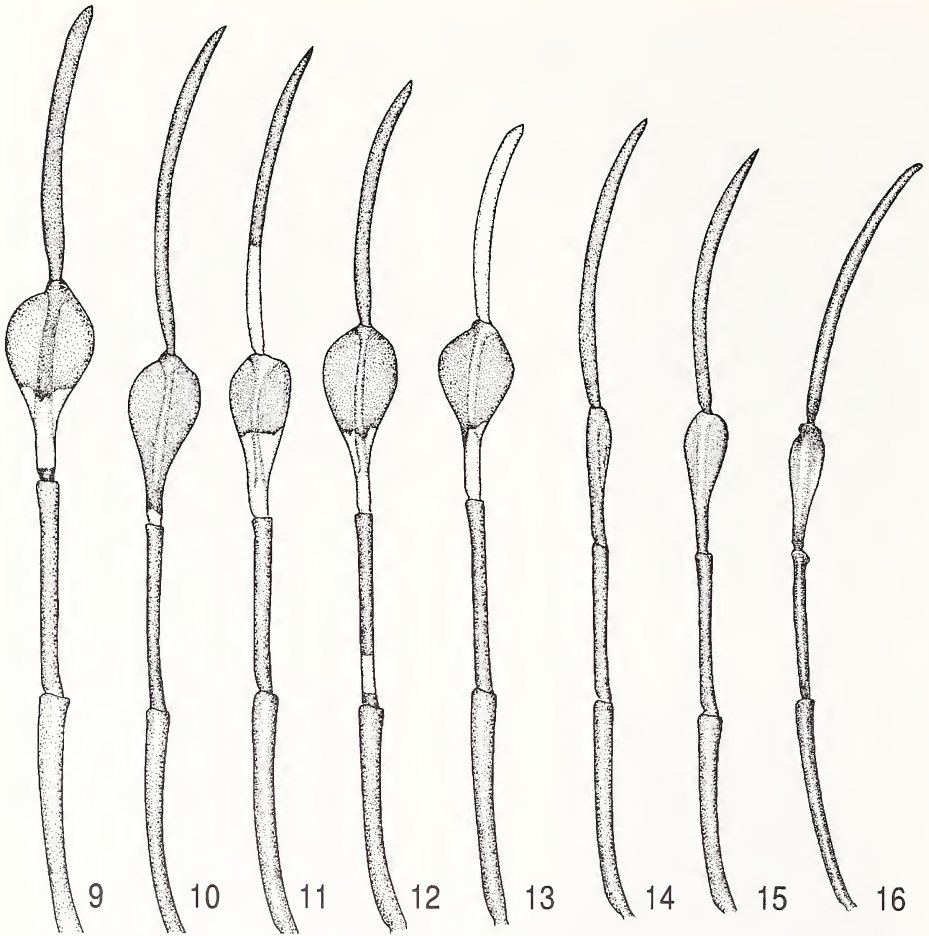

Figs. 9–16. Antennae of *Thasus* spp. (pale areas red-orange, stippled areas brown). 9. *T. gigas* (Klug). 10. *T. carchinus* sp.n. 11. *T. rutilus* sp.n. 12. *T. acutangulus* (Stål). 13. *T. neo-californicus* sp.n. 14. *T. heteropus* (Latreille). 15. *T. luteolus* sp.n. 16. *T. odonnellae* sp.n. (type).

The genera *Melucha* Amyot et Serville, 1843 and *Meluchamixia* Brailovsky, 1987 might also be confused with *Thasus*. Both are smaller than *Thasus*, however (*Melucha* less than 25 mm long, *Meluchamixia* about 25 mm long). The metatibia of *Melucha* is dilated, but the third antennal is not (O'Shea, 1980); also, the distance between the coxae in *Thasus* is nearly equal to the coxa-lateral margin distance, whereas in *Melucha* the intercoxal distance is much less (Stål, 1867). The metatibia of *Meluchamixia* is only slightly dilated, and the third antennal is asymmetrically dilated (Brailovsky, 1987).

Finally, *Vivianadema* Brailovsky, 1987, 31 mm long, is as large as some *Thasus* or *Pachylis*. However, the humeral angles of *Vivianadema* are very broadly produced, almost winglike (fig. 2, in Brailovsky, 1987).

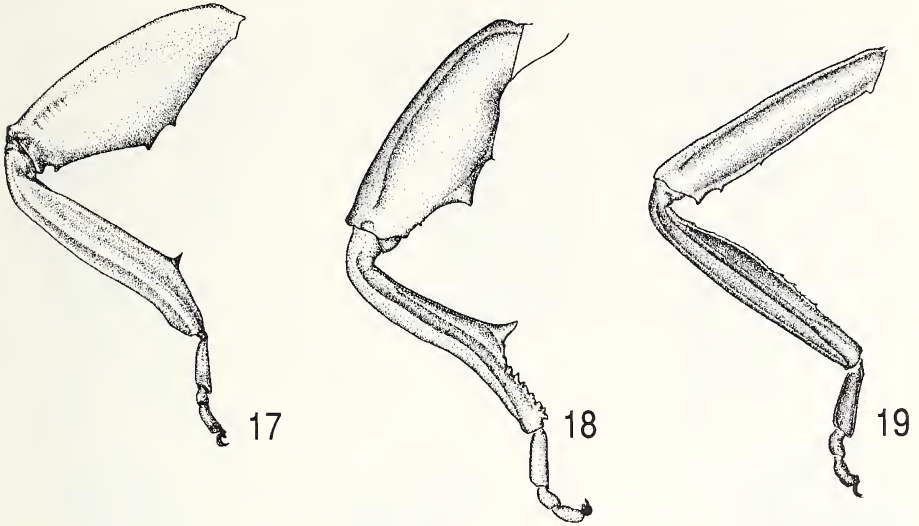

Figs. 17–19. Hind legs of *Thasus* spp. 17. *T. odonnellae*, male (type). 18. *T. gigas*, male. 19. *T. gigas*, female.

O'Shea (1980) gives a key to the nematopodine genera, although it does not include *Vivianadema* and *Meluchamixia*, both described in 1987. Brailovsky's key (1987) includes only species similar to *Thasus*; unfortunately, it omits *Pachylis*.

Discussion: *Pachylis* and *Thasus* have similar postocular tubercles (O'Shea, 1980), apparently an autapomorphy. We therefore believe these two to be sister groups.

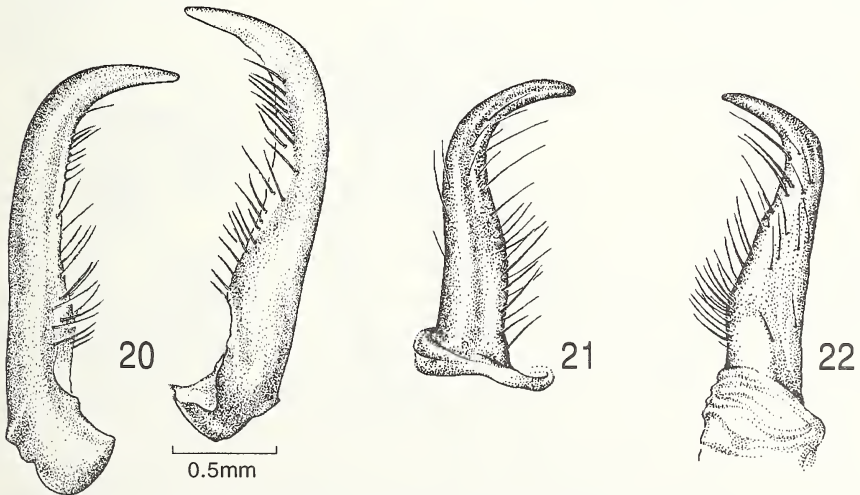

Figs. 20–22. Parameres of *Thasus* spp. 20. *T. gigas* (type) (two views). 21. *T. heteropus*. 22. *T. odonnellae* (type).

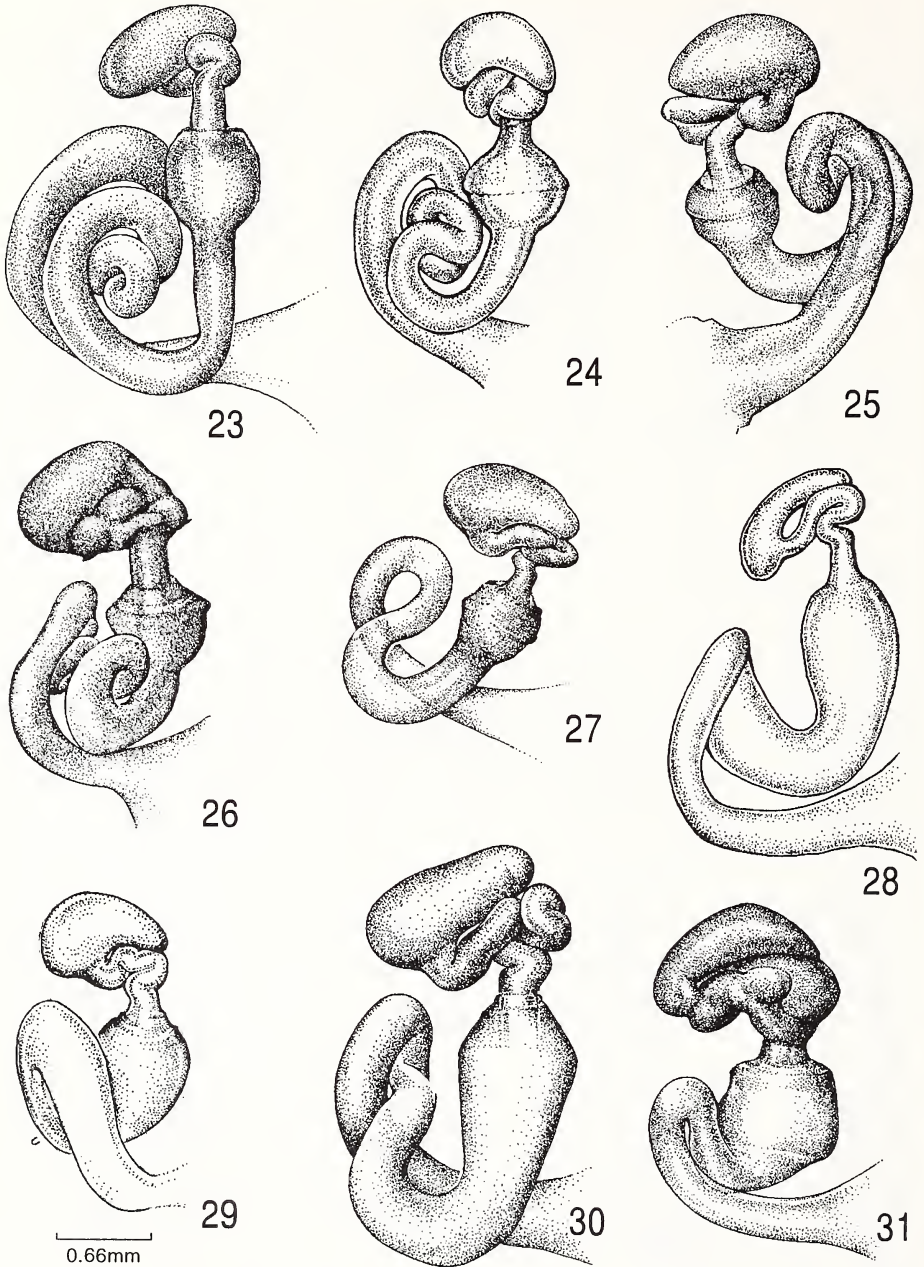

Figs. 23–31. Spermathecae of *Thasus* spp. and *Pachylis* spp. 23. *T. acutangulus* (type). 24. *T. gigas*. 25. *T. heteropus*. 26. *T. luteolus*. 27. *T. neocalifornicus*. 28. *T. odonnellae* (paratype). 29. *T. rutilus* (paratype). 30. *P. laticornis*. 31. *P. pharaonis*.

However, too little is known about the species in *Pachylis*, and thus about intrageneric variation, for us to be certain. For example, as in *Thasus*, both unicolorous *Pachylis* as well as *Pachylis* with yellow corial veins occur; but apparently only *P. laticornis annulipes* Blöte has banded legs (Blöte, 1938), like several *Thasus* species.

Further, the phylogenetic relationships of the genera likely to be close to *Thasus* remain unknown. A cladistic analysis is needed of the genera mentioned above.

KEY TO THE KNOWN SPECIES OF *THASUS*

1. Antennal 3 entirely dark brown, dilation narrow and elliptical (Figs. 14–16) 2
 Antennal 3 dark brown (*T. carchinus*) or bicolored, dilation broad (Figs. 9–13) 4
2. Connexival segments 4–7 dark brown, with yellow spots; clavus and corium with veins pale, contrasting with surface (Costa Rica) *T. luteolus* new species
 Connexival segments 4–7 dark brown, brown, or orange, without yellow spots; clavus and corium with veins unicolorous with surface 3
3. Humeral angles sharp; dilation of antennal 3 no more than 2× width of antennal 4; spine of fourth connexival segment barely visible; female's seventh connexival segment with or without very small spine (Colombia, Peru, Ecuador, Venezuela)
 *T. heteropus* (Latreille)
 Humeral angles obtuse; dilation of antennal 3 wider (at least 3× width of antennal 4); spine of fourth connexival segment small, visible; female's seventh connexivum with small spine (Bolivia) *T. odonnellae* new species
4. Antennal 4 orange-red or brownish orange-red, subequal in length to antennal 3 (Fig. 13) (U.S.A., Mexico) *T. neocalifornicus* new species
 Antennal 4 dark brown or sharply bicolored, longer than antennal 3 5
5. Antennal 2 red-orange basally and dark brown distally (Fig. 12) (Mexico, Guatemala, British Honduras, Costa Rica) *T. acutangulus* (Stål)
 Antennal 2 dark brown 6
6. Antennal 4 red-orange basally and dark brown distally (Fig. 11) (Peru, Brazil, French Guiana) *T. rutilus* new species
 Antennal 4 dark brown 7
7. Antennal 3 unicolorous (Fig. 10) (Ecuador) *T. carchinus* new species
 Antennal 3 red-orange basally and dark brown distally (Fig. 9) (Mexico, El Salvador) *T. gigas* (Klug)

Thasus acutangulus (Stål)

(Figs. 1, 12, 23)

Pachylis acutangula Stål, 1858:439

Redescription of holotype. Female. Color: Head black laterally, disk reddish-brown; ocelli ringed with black, and with yellow semicircle laterally. Antennal 1 deep reddish-brown, base and apex black; basal half of 2 and 3 orange, apical half black; 4 [missing in holotype, brown-black in other specimens]. Pronotum reddish-brown, callar region paler; collar and thin lateral line black, latter becoming yellow posteriorly; posterior edge yellow. Scutellum reddish-brown, lateral edges and apex yellow. Corium dark brown, veins yellow; membrane black. Connexival segments 3–7 dark reddish-brown posteriorly, orange anteriorly. Abdominal dorsum black. Thoracic pleura widely reddish-brown, each darkening to black near coxa and posterior edge. Anterior lobe

Table 1. Measurements (in mm) of species of *Thasus* (means and ranges).

	<i>T. acutangulus</i>			<i>T. gigas</i>			<i>T. heteropus</i>		
	Holo- type ♀ (N = 3)	♂ (N = 3)	Holo- type ♂ (N = 3)	♀ (N = 3)	♂ (N = 3)	♀ (N = 3)	♂ (N = 3)	♀ (N = 3)	♂ (N = 3)
Total length ¹	40.0	37.3 (34-40)	33.7 (32-34)	33.0	40.0 (40-41)	37.0 (36-39)	29.0 (26-31)	28.0 (28-29)	
Head width	3.2	3.3 (3.2-3.4)	3.2 (3.0-3.4)	3.6	3.4 (3.4-3.5)	3.3 (3.2-3.3)	2.7 (2.2-3.1)	2.9 (2.7-3.0)	
Head length from ocellar line	2.2	2.4 (2.2-2.5)	2.1 (1.8-2.3)	2.2	2.6 (2.3-3.0)	2.5 (2.3-2.7)	2.0 (1.8-2.2)	2.0 (1.8-2.1)	
Interocular width	1.8	1.8 (1.8)	1.7 (1.6-1.8)	2.0	2.8 (1.8-2.1)	1.9 (1.8-2.0)	1.6 (1.4-1.7)	1.6 (1.5-1.8)	
Interocellar width	0.8	1.0 (0.9-1.0)	0.9 (0.9)	1.4	1.3 (1.2-1.3)	1.3 (1.2-1.3)	0.8 (0.8-0.9)	0.9 (0.9-0.9)	
Pronotal width	14.9	13.0 (11.3-14.3)	12.9 (12.5-13.4)	13.4	12.8 (11.9-13.5)	11.7 (11.2-12.5)	12.1 (10.8-13.1)	12.9 (12.4-13.3)	
Scutellar width	4.7	4.9 (4.4-5.5)	4.6 (4.4-4.7)	4.9	5.1 (4.9-5.3)	5.0 (4.6-5.1)	3.8 (3.4-4.3)	4.4 (4.2-4.7)	
Scutellar length	4.6	4.4 (3.5-5.3)	3.8 (3.6-3.9)	4.7	4.8 (4.4-5.2)	4.5 (4.3-4.6)	3.8 (3.4-4.3)	4.2 (3.9-4.7)	
Antennal lengths									
I	6.5	7.0 (6.8-7.5)	6.3 (6.2-6.4)	7.9	7.4 (6.9-8.1)	6.6 (6.3-6.8)	5.0 (4.7-5.3)	5.0 (4.7-5.2)	
II	5.3	5.5 (5.3-5.7)	5.4 (5.2-5.5)	5.5	5.9 (5.6-6.2)	5.2 (4.7-5.6)	3.8 (3.6-4.4)	3.9 (3.9)	
III	5.3	5.4 (5.2-5.5)	5.0 (4.9-5.1)	5.5	5.5 (5.2-5.9)	5.1 (4.9-5.3)	3.4 (3.2-3.5)	3.1 (2.9-3.5)	
IV	—	8.2 (7.8-8.6)	7.5 (7.2-7.7)	7.5	6.6 (6.5-6.8)	6.4 (6.2-6.5)	6.8 (6.5-7.2)	6.3 (6.0-6.5)	
Maximal width of III	2.5	2.5 (2.5)	2.5 (2.3-2.6)	2.6	2.6 (2.5-2.7)	2.4 (2.2-2.5)	0.6 (0.5-0.8)	0.8 (0.8-0.8)	
Maximal width of hind tibia	2.7	2.7 (2.3-3.0)	2.8 (2.7-2.9)	2.5	2.7 (2.5-2.7)	2.0 (1.8-2.2)	2.0 (1.4-2.6)	2.0 (2.0-2.1)	

¹ From tip of tylus to tip of abdomen.

Table 1. Extended.

<i>T. car-</i> <i>chinus</i> holotype ♀	<i>T. luteolus</i>		<i>T. neocalifornicus</i>			<i>T. odonnellae</i>		<i>T. rutilus</i>	
	Holotype ♂	(N = 1)	Holotype ♂	(N = 3)	♀ (N = 3)	Holotype ♂	♀	Paratype (N = 2)	Paratype ♀
39.0	33.0	34.0	34.5	36.0 (35-36)	33.0 (32-34)	34.0	36.0	36.5 (36-37)	35.0
3.6	3.2	3.2	3.4	3.5 (3.4-3.6)	3.3 (3.1-3.6)	3.4	3.5	3.5 (3.4-3.6)	3.5
2.5	1.9	2.1	2.1	2.4 (2.3-2.5)	2.2 (2.1-2.3)	1.8	2.1	2.1 (2.0-2.2)	2.1
1.9	1.7	1.6	1.8	2.1 (2.0-2.2)	2.0 (1.8-2.1)	1.8	2.1	2.0 (2.0)	1.8
1.0	0.9	0.9	1.1	1.1 (1.0-1.2)	1.0 (0.9-1.0)	1.0	1.0	1.5 (1.0-1.1)	0.9
14.2	11.7	12.6	12.8	13.0 (12.6-13.2)	12.5 (11.3-13.6)	12.7	13.6	13.4 (12.7-14.0)	13.7
5.0	3.8	4.2	4.6	5.2 (4.6-6.3)	4.6 (4.3-4.8)	4.4	4.6	4.7 (4.6-4.8)	4.7
—	4.0	4.2	4.4	4.4 (4.0-4.6)	4.2 (4.1-4.4)	4.5	4.8	4.7 (4.6-4.8)	4.6
8.1	6.1	5.6	7.8	7.0 (6.6-7.4)	6.1 (6.0-6.2)	8.8	6.9	7.8 (N = 1)	7.2
5.9	4.9	4.8	6.5	5.9 (5.8-6.0)	5.4 (5.1-5.5)	5.6	5.1	5.2 (5.2)	5.2
5.2	4.2	4.3	5.6	5.5 (5.2-5.7)	5.0 (4.8-5.1)	4.6	4.6	5.0 (4.8-5.1)	4.9
9.6	7.9	—	6.1	5.7 (5.2-6.1)	5.0 (4.8-5.2)	10.0	10.4	9.4 (9.4)	8.8
2.1	1.2	1.3	2.0	2.3 (2.1-2.6)	2.0 (1.9-2.1)	1.3	1.3	1.8 (1.6-2.0)	2.0
3.0	2.0	2.1	2.1	2.5 (2.5-2.6)	2.0 (1.9-2.0)	2.2	2.6	2.0 (1.7-2.3)	1.6

of metathoracic scent gland opening black, bordered by yellow. Legs reddish-brown, apices and bases of segments black; tarsi black. Abdominal sterna reddish-brown, apicolateral borders of each black. Spiracle ringed with black. *Structure*: Apical $\frac{2}{3}$ of antennal 3 expanded, slightly asymmetrically. Pronotal rise about 60°; lateral edge crenulate; humeral angles acute. Connexivum exposed lateral to wings; connexival segments 3–7 with apicolateral spines, that on 3 very small; that on 7 smaller than that on 6. [Note: all other female specimens of *T. acutangulus* examined, lack a seventh-connexival spine.] Hind tibial expansion without large tooth, anterior margin smooth, posterior margin with small teeth; hind coxae with small protuberance; hind trochanter with small spine. Spermatheca: Figure 23.

Measurements: Table 1.

Holotype: In Naturhistoriska Riksmuseet (Stockholm).

Diagnosis: Recognized by its large size, humeral angles exposed, third antennal segment broad, obovate, and foliate, second antennal bicolored, fourth antennal brown to black (Fig. 12), and larger (usually above 7.30 mm), and femora and tibiae entirely black or bright orange with anterior and posterior third black and in each case without orange rings. Features which distinguish *T. acutangulus* from the related *T. gigas* and *T. neocalifornicus*, are discussed under these species.

Biology: According to Schaefer and Mitchell (1983), the food plant record of this species (Aldrich and Blum, 1978) should refer to *Pachylis laticornis* (F.).

Distribution: MEXICO: Veracruz: Orizaba and Misantla. GUATEMALA: Senahu and Cerro Zunil. BRITISH HONDURAS: River Sarstoon. COSTA RICA: Guanacaste (probably misidentification) (Distant, 1881–1892; Aldrich and Blum, 1978; Walker, 1871). The records from the United States are misidentifications (see discussion of *Thasus neocalifornicus*).

New records: MEXICO: Veracruz: Dos Amates, Zongolica, Jalapa, Cordoba, Fortin de las Flores and Coscomatepec. Guerrero: Coyuca. Jalisco: Chamela. Oaxaca: Portillo del Rayo. Estado de Mexico: Malinalco. Morelos: Tepoztlan and Jonacatepec. San Luis Potosi: Xilitla.

Thasus carchinus, Brailovsky & Barrera, n. sp.

(Figs. 2, 10)

Description. Female. Color: Head, including antennals 1–4, pronotum, scutellum, and abdominal terga black with following areas yellow or orange red: space between ocellus-eye, posterolateral border including spine of humeral angle of pronotum, a very small discoidal dot on middle of posterior border of pronotum, and apex of scutellum. Clavus and corium red brown to black, with following areas pale yellow: claval and corial veins, claval commissure, posterior half of anal edge, costal margin, apical angle and apical margin of corium, and a few scattered spots between corial veins. Hemelytral membrane dark chestnut brown with blue and violet metallic iridescence and with basal angle and veins darker. Connexival segments 2–9 with dorsal surface and spines yellow, ventral surface black; segments 2, 3, 8, 9 black, segments 5–7 yellow with posterior third black. Body ventrally black with following areas pale yellow or dark orange ochre: small dot in middle head region, mesopleuron, venter of trochanter, incomplete ring on apical third of femur, mesial body of tibia, pleural margin of abdominal sterna 3–7 (posterior third always black), and sternum

7 with large irregular spot on each side of midline. *Structure*: Dilation of third antennal segment broadly obovate and foliate; anterolateral border of prothorax nodulose; humeral angles exposed, ending in large robust spine; posterior tibiae much dilated and lanceolate, both inner and outer margins entire; posterior angle of connexival segments 4–7 each with short acute spine.

Measurements: Table 1.

Holotype. Female. ECUADOR: Province Carchi: Pallon, 1,030 m, IX-X. 1983. Deposited in CMP.

Diagnosis: This species agrees with *T. acutangulus*, *T. gigas*, and *T. neocalifornicus* in the shape of the third antennal segment, which is broadly obovate and foliate (Figs. 9, 10, 12). *T. carchinus*, new species, is recognized by the contrasting coloration of its tibiae and connexival segments, which are mostly yellow; and by the ventral body mostly black except the yellow pleural margins of abdominal sternites 3–7 (posterior third always black). The color patterns of the other species are quite distinct.

Etymology: Named for the type locality, Carchi Province, Ecuador.

Thasus gigas (Klug)

(Figs. 3, 9, 18, 19, 20, 24)

Pachylis gigas Burmeister, 1835:338

Redescription of holotype. Male: Color: Head black, with yellow-white semicircle lateral to each ocellus. Antennal segments brown-black, except 3 orange basally. Pronotum reddish-brown, except callar area black, lateral irregularly oval area pale reddish-brown. Scutellum shining mahogany, edges and apex yellow, anteromedially light reddish-brown. Corium dull mahogany, veins yellow; membrane brown-black. Connexiva brown-black, 3–7 with orange spot basolaterally. Abdominal dorsum orange, except tergum 2 and apex of 7 black. Thoracic pleura brown, yellow spot on propleuron at end of pleural suture, and yellow fascia anteriorly across meso- and metapleura. Anterior lobe of metathoracic scent gland opening black. Legs brown; all femora with two yellow rings, subbasally and subapically; coxae yellow basally. Abdominal sterna orange-red anteriorly, darkening to black posteriorly; 7 entirely black medially. Spiracle ringed with black, this black extending posteriorly from spiracle (and anteriorly on sternum 3). *Structure*: Apical $\frac{2}{3}$ of antennal 3 expanded, slightly asymmetrically. Pronotal rise about 50°; lateral edge with minute spines; humeral angles very obtuse, almost rounded. Connexivum more or less exposed lateral to wings; terga 4–7 with apicolateral spines, progressively longer. Hind tibial expansion with large sharp tooth; hind coxa with large lobelike protuberance; hind trochanter with large blunt spine. Paramere: Figure 19. Spermatheca: Figure 24.

Measurements: Table 1.

Holotype: In Museum für Naturkunde der Humboldt-Universität zu Berlin.

Diagnosis: This handsome species is similar in color and general habitus to *T. acutangulus* (Stål), but differs in having humeral angles rounded and obtuse, second antennal entirely brown (Fig. 9), pronotum barely declivent (45° to 50°), posterior angle of connexival segment 7 of female with a large spine, and in both sexes femora and tibiae with orange-red rings. In *T. acutangulus* the humeral angles are exposed, second antennal bicolored (Fig. 12), pronotum more declivent (>50°), posterior angle

of connexival segment 7 of female truncated, and femora and tibiae without orange red rings. See under *T. neocalifornicus* for differences between these two species. Note: in very dark specimens, the banding of the tibiae and femora may be obscured, as may be other areas where, in paler specimens, yellow or orange occurs. *Biology*: In Tehuacán, in the Mexican state of Puebla, two of the present authors, together with Cristina Mayorga and Guillermina Ortega, collected this species on mesquite (*Prosopis laevigata*); nymphs are bright orange yellow and black and live closely aggregated; the adults are not gregarious.

Distribution: MEXICO: Nayarit: Tepic. Guerrero: Xucumanatlan and Omilteme. Veracruz: Orizaba. (Distant, 1881–1892; Walker, 1871). The records from the United States (Arizona) are misidentifications (see discussion of *Thasus neocalifornicus*).

New records: MEXICO: Tamaulipas: km 91 carr. Tula-Ciudad Victoria. Sinaloa: Fuerte. Zacatecas: San Francisco. Durango: Nombre de Dios. Aguascalientes: Ciudad de Aguascalientes. Nayarit: Sierra San Juan. Jalisco: La Floresta (Lago de Chapala). Queretaro: Montenegro, Tequisquiapan, Ciudad de Queretaro and 10 mi N of Ciudad de Queretaro. Hidalgo: Tasquillo, Jacala, Don Guiño, Santiago de Anaya. Guanajuato: San Miguel de Allende, Ciudad de Guanajuato, Celaya. Puebla: Matamoros, km 75 carr. Tehuacan-Huajuapán de Leon, Tehuacan. Morelos: Tepoztlan, km 83 carr. Cuernavaca-Tepoztlan, Cañon de Lobos, Cuernavaca, Las Estacas. Colima: Ciudad de Colima. Estado de Mexico: Pto. Los Gallos and 28 mi W of Toluca. Oaxaca: Ciudad de Oaxaca, Montealban, Mitla, Huajuapán de Leon, Ixtlan, Teotitlan del Valle, and km 40 carr. Oaxaca-Gelatao. Michoacan: Petatan, Acambaro, 20 km, W of Zitacuaro, Morelia, Jiquilpan, Cuitzeo. Guerrero: Rodecia, Teloloapan, Cañon del Zopilote, Estacion de Microondas Tuxpan and 11 mi N of Ixtapan de la Sal. Vera Cruz: 5 mi E of Acultzingo. Distrito Federal: Tonicaco. EL SALVADOR: Puerto La Libertad.

Thasus heteropus (Latreille)

(Figs. 4, 14, 21, 25, 32)

Coreus heteropus Latreille, 1811:189

Redescription. Male. Color: Dorsum, antennae, dorsal surface of legs, brown to deep brown, almost black; membrane darker. Dorsum (including exposed lateral margins of abdominal terga), legs, and antennae, but not membrane, heavily beset with short, recumbent, golden setae. Venter sometimes lighter brown, especially ventral surfaces of legs. Venter sparsely beset with golden setae. Thoracic pleura each with discoidal patch of long, dense, recumbent golden setae, just lateral to subcoxae. *Structure*: Apical half of antennal 3 only slightly dilated, asymmetrically. Pronotal rise about 45°, humeral angles with small sharp tooth, lateral margins of pronotum slightly crenulate. Abdominal terga more or less exposed lateral to wings; terga 4–7 with small blunt spines apicolaterally, those on 4 and 7 very small. Rostrum nearly attaining metasternum. Hind tibial expansion without tooth; hind coxae with round protuberance; hind trochanter with small blunt spine.

Female: as male, except hind coxa and trochanter with slight round protuberances. Plica of seventh sternum with very small blunt tooth.

Measurements: Table 1.

Holotype: We have been unable to locate the holotype of this species.

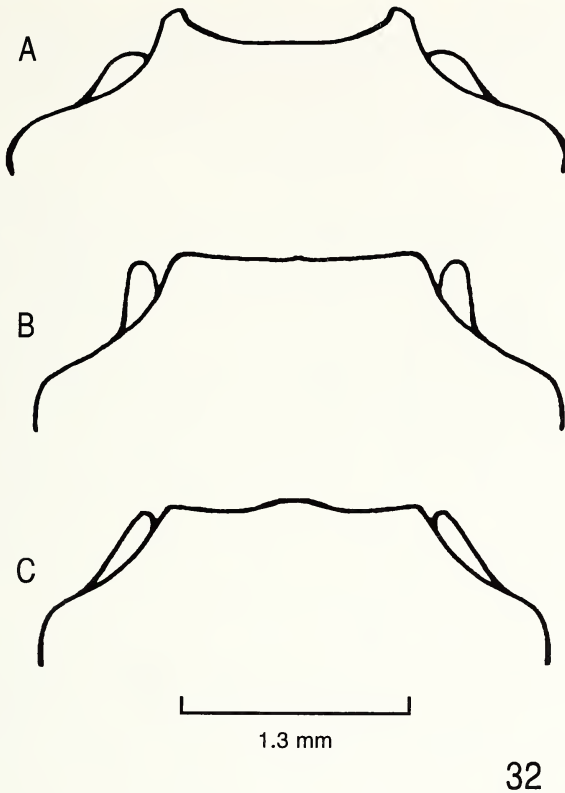

32

Fig. 32A–C. Variation in ventral rims of *Thasus heteropus* genital capsules; dorsal views. A. Representing specimens from Argentina, Ecuador (small hind femora), Venezuela, no locality on label. B. Peru, Ecuador (normal hind femora, 2 specimens). C. Colombia.

Variation: Nearly all specimens examined are dark brown to near black, but a few are somewhat lighter, to light brown. In addition, the hind femora of one male from Ecuador are much less incrassate than the hind femora of other males (including several from Ecuador); its hind femora however are more incrassate than those of any female. Males vary also in the size and shape of the genital capsule's ventral rim: in some the median excision is deeper than in others; and the lobes lateral and interior to the edges of the excision vary in shape (Fig. 32). The capsule of the Ecuador male with small hind femora differs from those of two Ecuador specimens with "normal" hind femora (Fig. 32A, B). The seventh connexival segment of the female may have or lack a tiny lateral spine.

Diagnosis: This species has the third antennal entirely black, with the dilated portion narrow and elliptical (Fig. 14). Claval and corial veins are unicolorous with the corial surface. For other features, see under *T. odonnellae*.

Distribution: COLOMBIA: Bogota, Nova Granada. ECUADOR: Santa Cecilia (Dallas, 1852; Froeschner, 1981; Stål, 1870; Walker, 1871).

New records: COLOMBIA: Santa Elena, Gigante (Huila Prov.), "de Savannah de Bogota." ECUADOR: Alóao, Balzapamba, Chiriboga, Interandins, LaVega, Portoviejo, Rio Toachi. PERU: Chanchamayo. VENEZUELA: Carbonera, Mucuruba.

***Thasus luteolus*, Brailovsky & Barrera, n. sp.**

(Figs. 5, 15, 26)

Description. Male: Color: Head including antennals 1–4 black, yellow between ocellus and eye. Pronotum reddish-brown, anterior margin, anterolateral edge, posterior margin black, posterolateral margin and spine of humeral angle pale yellow, callus with two orange irregular spots on each side of midline. Scutellum bright reddish-brown, with apex black and lateral edge pale yellow. Clavus and corium reddish-brown with following areas pale yellow: claval and corial veins, claval commissure, posterior half of anal edge, costal margin, apical angle, apical margin of corium. Hemelytral membrane chestnut brown, basal angle and veins darker. Connexival segment 2 entirely black, 3 and 4 black with anterodorsal edge yellow, 5–7 with anterior third yellow and the rest including the spines black; abdominal terga black. Ventrally, head and rostral segments black; prosternum black, mesosternum black with median discoidal orange spot, metasternum orange with anterior and lateral edges black; propleuron black with two orange spots, one near acetabulae, the other running below anterolateral edge. Mesopleuron orange with external and inferior margins black; metapleuron orange with posterodorsal angle black. Anterior lobe of metathoracic scent gland dirty yellow, posterior lobe and neighboring areas black. Fore and middle acetabulae black, with an elongate orange spot; posterior acetabulae orange with superior, external, and inferior edges black. Coxae bright orange with inferior edge black; trochanters black laterally, bright orange medially. Fore and middle femora black, with two orange rings, one basal, the other subdistal; posterior femora reddish-brown basally, an incomplete subdistal ring orange; fore and middle tibiae black with medial yellow spot; external dilation on posterior tibiae black with elongate yellow spot near middle, internal dilation with anterior half yellow and posterior half black and with elongate yellow spot near middle; tarsi black. Abdominal sternites bright orange, posterior edge of sternum 7, spiracles black. Pleural margin 2 entirely black, 3–7 with anterior margin or anterior half yellow and the rest including spines black. *Structure:* Dilation of third antennal segment narrowly elliptical to lanceolated in outline. Anterolateral border of prothorax with small spines to nodulose; humeral angles wider, relatively exposed, with slight spine. Posterior tibiae dilated, lanceolate, inner dilation with broad spine. Posterior angles of connexival segments 4–7 with large spine. Posteroventral border of genital capsule with four short extensions, lateral ones robust and slightly exposed, middle ones quadrate and a small concave space between.

Female: Color: Similar to male. Posterior tibiae black with elongate yellow spot on external dilation and on internal dilation. Connexival segments 8 and 9, and abdominal terga 8 and 9, black. Gonocoxa 2 black with orange red spot on external angle, another on middle basal side. Paratergite 8 black; paratergite 9 orange with upper edge dark brown. Spermatheca: Figure 26. *Structure:* Posterior tibiae dilated and lanceolate, margins entire; posterior angles of connexival segments 4–6 each with small spine, segment 7 truncate without spine.

Measurements: Table 1.

Variation: 1. Mesosternum, metasternum, and acetabulae entirely black. 2. Fore and middle trochanters almost black. 3. Fore and middle femora black, with two incomplete and diffuse dirty orange rings. 4. Abdominal sternum black with anterior half lateral to middle line dark orange red. 5. Gonocoxae 1 black with external and basal margin yellow. 6. Paratergite 8 black with a median and internal yellow spot.

Holotype: Male. COSTA RICA: Provincia San Jose: Uruca, 13.XII. 1981, L. Alvarez. Deposited in IBUNAM.

Paratypes. One female: COSTA RICA: Provincia Cartago: Orosi, 20.I. 1980, Helga Blanco. Deposited in UCCR. One female: COSTA RICA: Provincia Cartago: El Llano, 1.VII. 1983, Fdo. Vazquez. Deposited in IBUNAM.

Diagnosis: Like *T. heteropus*, *T. luteolus* has the second antennal entirely black, and its dilation small (Figs. 14, 15). In *T. luteolus*, connexival segments 4–7 are black with an anterior yellow spot, clavus and corium with pale yellow veins, contrasting with the brown red surface, tibiae black with middle yellow spot, and pronotum slightly declivent. In *T. heteropus*, the connexival segments and tibiae are entirely brown to brown-orange or black, the clavus and corium (including veins) are unicolorous, and the pronotum is more declivent.

Etymology. Named for the yellow spot on the tibiae.

***Thasus neocalifornicus*, Brailovsky & Barrera, n. sp.**

(Figs. 6, 13, 27)

Pachylis gigas: Uhler, 1875:831 (misidentification)

Pachylis gigas: Uhler, 1876:295 (misidentification)

Pachylis gigas: Uhler, 1877:1325 (misidentification)

Thasus gigas: Distant, 1881:108 (partial misidentification)

Pachylis gigas: Uhler, 1886:10 (misidentification)

Pachylis gigas: Uhler, 1894:232–233 (misidentification)

Thasus gigas: Van Duzee, 1917:92–93 (misidentification)

Thasus gigas: Van Duzee, 1923:132 (misidentification)

Thasus acutangulus: Torre Bueno, 1940a:45 (misidentification)

Thasus gigas: Torre Bueno, 1940b:102 (misidentification)

Thasus acutangulus: Torre Bueno, 1941:54 (misidentification)

Thasus gigas or *acutangulus*?: Torre Bueno, 1942:184 (misidentification)

Thasus acutangulus: Torre Bueno, 1945:83 (misidentification)

Thasus gigas: O'Shea, 1980:219 (partial misidentification)

Thasus acutangula: O'Shea, 1980:219 (partial misidentification)

Description. Male. Color: Head shiny black, space between ocellus and eye dark orange. Antennal 1 shiny black, 2 shiny black with bright reddish reflections on basal third, 3 bright orange with dilated area shiny black, 4 dull orange red. Pronotum, scutellum bright brown to black, with reddish reflections. Clavus, corium dark brown, with following areas pale yellow: claval and corial veins, apical third of anal border, claval commissure, costal margin, apical angle, apical margin, and a few scattered spots between corial veins; membrane brown amber with veins and basal angle darker. Connexival segments 2–4 dark reddish-brown, segments 5–7 bicolored, anterior third or anterior half bright orange red and posterior half dark brown red, always with spines and superior margin shiny black. Abdominal terga bright orange red, posterior

half of segment 7 dark brown red. Head dull orange ventrally, bucculae and rostral segments dark brown red. Pleuron dark brown red, with three or four bright red orange areas, one or two on propleuron and one each on mesopleuron and meta-pleuron. Anterior and posterior lobes of metathoracic scent gland black with dark orange reflections. Coxae bright orange, apical third shiny black; trochanters black with bright orange reflections; femora black with two bright orange-red rings, one basal, the other near apical third; tibiae black with two bright orange-red incomplete rings, one near basal third, other near apical third; tarsi shiny black. Abdominal sterna dark orange red, posterior third or posterior half mostly black; pleural margins 2-4 orange red and 5-7 with anterior third or anterior half, orange red, the rest (including dorsal border and spines) black. Genital capsule black, laterally dark orange red. *Structure*: Dilation of antennal 3 broad, obovate, foliate. Pronotum conspicuously declivent, inclination 50°-56°; anterolateral border with small spines; humeral angles exposed, apex somewhat projected as a spine. Posterior tibiae slightly dilated and lanceolate, inner dilation with broad spine. Posterior angles of connexival segments 4-7 with small to large spines. Posteroventral border of genital capsule with four long arms, lateral ones broad, quadrated, and apically truncated, middle ones shorter and globose, and large medial straight space between.

Female: *Color*: Similar to male. Connexival segment 8 black, 9 bright orange red with posterior angle black; abdominal terga 8 and 9 with anterior half bright orange red and posterior half black; gonocoxae 1 and paratergite 8 black with basal third bright orange red; paratergite 9 with anterior half bright orange red and posterior half black.

Structure: Posterior tibiae slightly dilated and lanceolated, all margins entire; posterior angles of connexival segments 4-7 with small to large spines. Spermatheca: Figure 27.

Measurements: Table 1.

Variation: 1. Antennal 2 black with basal third bright orange red. 2. Antennal 3 black. 3. Antennal 4 dark orange, or pale brown orange, or mottled with dark brown. 4. Trochanters bright orange red. 5. Anterior lobe of metathoracic scent gland dirty ochre. 6. Pleura uniformly dark brown red. 7. Abdominal sternites, including pleural margins and genital plates of female, bright pale red and with only superior border and spines shiny black. Note: In very dark specimens, the banding of the tibiae and femora may be obscured, as may be other areas where, in paler specimens, yellow or orange occurs. Indeed, we have two specimens collected on the same day at the same place in Arizona; one has the banding and the other, much darker, does not.

Holotype: Male. MEXICO: Baja California Sur: km 75.5 carr. La Paz—San Jose del Cabo, 11.IX. 1977, R. Lopez. Deposited in IBUNAM.

Paratypes. Two males and three females. Same data as holotype. Deposited in CAS, TAMU, IBUNAM. Two males, one female: MEXICO: Baja California Sur: Todos Santos, 5.VIII. 1984, A. Martinez. Deposited in IBUNAM. Four males, two females: MEXICO: Baja California Sur: 15 km, SE de El Triunfo, 15.VII. 1982, E. Barrera and H. Brailovsky. Deposited in AMNH, BMNH, and IBUNAM. One male: MEXICO: Baja California Sur: Mulege, 12.VIII. 1981, E. Barrera. Deposited in IBUNAM. Three males, three females: MEXICO: Baja California Sur: km 75 carr. Cabo San Lucas—La Paz, 11.IX. 1977, M. Santamaria. Deposited in AMNH, CAS, USNM, IBUNAM. One female: MEXICO: Baja California Sur: La Paz, 10.IX. 1959, D. R. Estes. Deposited in FSCA. Two males, one female: MEXICO: Baja California Sur:

1 km east of E. Triunfo (533 m), 27.VII. 1974, R. M. Haradon, W. E. Savary, V. F. Lee. Deposited in UCB. One male: MEXICO: Baja California Sur: La Paz (Hotel Guaycura), X.1929. Deposited in CMP. One female: MEXICO: Sonora: Santa Ana, 3.XI. 1986, F.Arias. Deposited in IBUNAM. Two females: UNITED STATES: Arizona: Pima Co., Tucson, 29.VII. 1969. Deposited in FMNH. One male: UNITED STATES: Arizona: Santa Cruz Madera, without data. Deposited in FSCA. Two males, two females: UNITED STATES: Arizona: Cochise Co., 7 mi W, Benson, 1.IX. 1968, J. B. Heppner. Deposited in FSCA. One male: UNITED STATES: Arizona: Santa Cruz Co., Peña Blanca Cyn., (4,200 ft) 1.VIII. 1974, S. Szerlip. Deposited in UCB. Four males and one female: UNITED STATES: Arizona: Pima Co., Florida Cn., 3. VIII. 1983, S. Ziff. Deposited in LACM and IBUNAM.

Discussion: There has been uncertainty in the literature over the species of *Thasus* occurring north of Mexico. Uhler reported *Pachylis gigas* for this region (1875, 1876, 1877, 1886, 1894), and this was followed by Van Duzee (1917, 1923). In 1940 (a), Torre Bueno reported *Thasus acutangula* from Arizona, but later in that year (1940b), using notes from Barber, he changed his identification to *Thasus gigas*. Later (1941), he listed *T. acutangula* from Arizona and New Mexico and rejected *T. gigas* as probably a misidentification; the following year Torre Bueno (1942) expressed doubts about Van Duzee's (1923) use of *gigas* and suggested *acutangulus*. O'Shea (1980) listed both forms from the United States without any clarifying comment. Recently, Froeschner (1988) referred again to the subject and discussed it briefly; he decided to conserve *T. gigas* as probably the North American species.

Examining the extensive collection of *Thasus* housed in IBUNAM as well as much material from other American collections, we (H.B. and E.B.) realized that a new species, closely related to the other two, was involved. This new species is distributed in the northwest of Mexico, and in Arizona and New Mexico. The other two species (*T. gigas* and *acutangulus*) are more southern.

Thasus neocalifornicus is more closely related to *T. gigas* (Burmeister) and *T. acutangulus* (Stål), sharing the antennal segment 3 obovate, conspicuously dilated, foliate, and bicolored (Figs. 9, 12, 13).

The following combination of characters will serve to separate *T. neocalifornicus* from *T. gigas*: body large and relatively slender, antennal 4 dull orange red and shorter (usually under 6.20 mm), humeral angles exposed, with apical spine somewhat pointed, ventral head dull orange, maximal width of abdomen less than 12.30 mm, antennal 2 bicolored, pronotum much declivent (50° to 56°). In *T. gigas* the body is large and broad, antennal 4 brown or black (but sometimes reddish-brown) and larger (usually above 6.30 mm), humeral angles obtuse and rounded, ventral head black, maximal width of abdomen above 13.00 mm, antennal 2 entirely black, and pronotum barely declivent (45° to 50°).

The females of *T. neocalifornicus* and *T. gigas* are alike in color of femora and tibiae and development of the ventral and dorsal dilation of the posterior tibiae, whose maximal width is usually less than 2.75 mm; and the posterior angles of their connexival segments 7 have a long spine.

In *T. acutangulus* the maximal width of the posterior tibiae is usually more than 2.80 mm, and the posterior angle of the female's connexival segment 7 is truncated, without a spine. The bicolored antennal 2 and the remarkably declivent pronotum ally *T. neocalifornicus* and *T. acutangulus*. The following combination of characters

will serve to separate these species. In *T. neocalifornicus*, antennal 4 is dull orange red and shorter (usually under 6.20 mm) and femora and tibiae have orange red rings. In *T. acutangulus* antennal 4 is brown to black and larger (usually above 7.20 mm); width of abdomen above 13.85 mm; and the femora and tibiae are entirely black or bright orange, with the anterior and posterior third black and without orange rings.

Finally, this is the only species of *Thasus* (or, as far as we know, of *Pachylis*) in which antennals 3 and 4 are subequal; in all other species, 4 is longer than 3 (Table 1). This character (subequality of 3 and 4) does not appear to vary.

Etymology: Named for its occurrence in the Baja California Region.

Biology: Jones (1993) gives the most complete account available of the biology of this species (in several localities in Arizona). Eggs are laid in chains of a dozen or so, concealed in or under stems and loose bark of the host plant, the legume velvet mesquite (*Prosopis velutina* Woot.). All instars are gregarious.

***Thasus odonnellae*, Schaefer & Packauskas, n. sp.**

(Figs. 7, 16, 17, 22, 28)

Description. Holotype male: Color: Dorsum, antennae, brown; legs deep red-brown; membrane darker. Dorsum (including exposed lateral margins of abdomen) heavily beset with short recumbent golden setae, these heavily concentrated along lateral margins of prothorax. Venter deep red-brown, the following areas dark brown to black: auricle of metathoracic scent gland, base of coxae, apex of femur, rostral 4, spines of hind tibia and of abdominal segments, incomplete irregular medial stripe on metasternum. Spiracles narrowly ringed with yellow. Venter lightly beset with golden setae. Thoracic pleura each with discoidal patch of long, dense, recumbent, golden setae, just lateral to subcoxae. *Structure*: Apical two-thirds of antennal 3 moderately dilated, asymmetrically. Pronotal rise about 50°; anterior half of lateral margins of pronotum smooth; posterior half with several very small teeth; humeral angles blunt. Abdominal terga narrowly exposed lateral to wings; terga 4–7 with small sharp spines apicolaterally. Hind tibial expansion with median tooth. Hind coxa and trochanter each with blunt fingerlike protuberance, that of trochanter smaller. Paramere: Figure 21.

Paratype female: As male, except more heavily beset with golden setae both dorsally and ventrally, except pronotal collar and calli nearly bare; scent gland auricle, coxal spine red-brown (concolorous with venter), and without medial metasternal stripe. Spiracles not ringed with yellow. Abdominal terga more broadly exposed laterally. Without spines on hind tibia and trochanter, hind-coxal protuberance slight. Plica of seventh sternum with small blunt spines. Spermatheca: Figure 25.

Measurements: Table 1.

Diagnosis: Most similar to *T. heteropus*, from which it differs in the greater development of both the antennal and the hind-tibial dilations, and of the hind-tibial, abdominal tergal, and plical spines; the more blunt humeral angles; the heavier coating of golden setae (especially in the female); the generally lighter coloration (although some *T. heteropus* are as light as *T. odonnellae*, and other specimens of the latter may prove to be darker than these types).

Type locality: BOLIVIA: Rio Cristal Maru.

Label data: holotype male: label 1) Rio Cristal Maru 50 mi/ NE Cochabamba, Bolivia/

X-15-1949/ Collector: A Pena. 2) J. C. Lutz/ Collection/ 1961. Right antenna point-mounted separately on pin; genitalia in vial on pin. Paratype female: 1) same, except X-31-1949. 2) Same. Both specimens in NMNH.

Variation: We have a third specimen of this species, a female (from CU) lacking any locality information. This female has the black auricle and yellow-ringed spiracles of the holotype male; the paratype female lacks both these features.

Etymology: This species is named for Dr. J. E. O'Donnell, in recognition of her contributions to the study of Heteroptera, and of her aid to entomologists as curator of the University of Connecticut Insect Collection.

***Thasus rutilus*, Brailovsky & Barrera, n. sp.**

(Figs. 8, 11, 29)

Description. Male: Color: Dorsum dark reddish-brown, with anterolateral edge of pronotum and transverse ridge of pronotal disk darker and following areas dark orange ochre: space between ocellus and eye, lateral edge and apex of scutellum, claval and corial veins, claval commissure, costal margin, apical angle and apical margin of corium. Antennals 1 and 2 entirely black, 3 and 4 bicolored, with anterior half pale orange yellow and posterior half black. Hemelytral membrane dark ambarine, with basal angle and veins darker. Connexival segment 2 entirely pale orange yellow, 3 reddish-brown with superior edge pale orange yellow, 4–7 reddish-brown with shiny black spines. Abdominal terga 1–6 pale orange red, 7 orange red with a central black spot. Venter pale chestnut orange. Rostral segments 1–3 dark chestnut orange, 4 black. Pleural margins of abdominal sternum 2 entirely pale yellow, 3 pale chestnut orange with central yellow spot, 4–7 pale chestnut orange with lateral edges and spines black. Coxae and trochanters pale chestnut orange with bright red reflections; femora pale orange red, with apical edge black; tibiae dark orange with subdistal third black or darker; tarsi pale orange. *Structure:* Dilation of antennal 3 broadly obovate and foliate. Anterolateral border of pronotum nodulose; humeral angle broadly exposed, ending in obtuse spine. Posterior tibiae dilated, lanceolate, inner dilation with large spine. Posterior angles of connexival segments 4–7 each with large spine. Posteroventral border of genital capsule with large bilobed medial plate, laterally delimited by short and globose projection.

Female: Color: Similar to male. Connexival segments 8 and 9 and abdominal terga 8 and 9 reddish-brown; black central spot on tergum 8; posterior edge of tergum 9 black. Genital plates entirely pale chestnut orange. *Structure:* Posterior tibiae slightly dilated and lanceolate, both inner and outer margins entire. Posterior angle of connexival segments 4–7 each with large spine. Spermatheca: Figure 29.

Measurements: Table 1.

Variation: 1. Connexival segments 3–9 bright orange red, dorsal border and spines black. 2. Abdominal terga 1–6 bright orange yellow. 3. Ventral surface pale orange yellow with acetabulae chestnut orange.

Holotype. Male. BRAZIL: Mato Grosso: Sinop, X. 1976, M. Alvarenga. Deposited in CMP.

Paratypes. Nine males, twelve females. Same data as holotype. Deposited in CMP and IBUNAM. One male: BRAZIL: Mato Grosso: Diamantino, Fazenda Sao Joao (450 m), 8.II. 1981, G. Ekis. Deposited in CMP. Two males: FRENCH GUIANA: Mana River, X. 1917 (acc. 6008). Deposited in CMP. One female: PERU: Madre

Table 2. Character states, polarities, and distributions of *Thasus* and *Pachylis*.

Character	<i>T. acutangulus</i>	<i>T. gigas</i>	<i>T. neocalifornicus</i>	<i>T. heteropus</i>	<i>T. odonellae</i>
a. Metatibial dilation	symmetrical (1)	symmetrical (1)	symmetrical (1)	symmetrical (1)	symmetrical (1)
b. Pale hirsute spots on pleura	absent (2)	absent (2)	absent (2)	large (1)	large (1)
c. Female connexival VII spine	absent (0)	present (1)	present (1)	present (very small) (1)	present (1)
d. Antennal III dilation	symmetrical (1)	symmetrical (1)	symmetrical (1)	asymmetrical (0)	asymmetrical (0)
e. Antennal III dilation	large (0)	large (0)	large (0)	small (1)	small (1)
f. Humeral angle	sharp (1)	rounded (0)	sharp (1)	sharp (1)	subacute (0)
g. Metatrochanter spine	small (1)	large (0)	large (0)	small (1)	small (1)
h. Female sternum VII spine	absent (0)	present (1)	present (1)	present (very small) (1)	present (1)
i. Second valvula tooth	broadly rounded (1 ^a)	asymetrically bifid, both tips rounded (2)	broad, slight indentation (2)	obtuse (1 ^b)	sharp (0)
j. Corial veins	dark (0) or bright (1 ^a)	bright (1 ^a)	bright (1 ^a)	dark (0)	dark (0)
Distribution	Mexico, no. Central Amer.	Mexico, Central Amer.	no. Mexico, s.w. U.S.	no. S. Amer.	Bolivia

Table 2. Extended.

	<i>T. luteolus</i>	<i>T. carchinus</i>	<i>T. rutilus</i>	<i>P. laticornis</i>	<i>P. pharaonis</i>	<i>P. spp.</i>
symmetrical (1)	symmetrical (1)	symmetrical (1)	symmetrical (1)	asymmetrical (0)	asymmetrical (0)	asymmetrical (0)
absent (2)	absent (2)	absent (2)	large (1)	tiny (0)	tiny (0)	tiny (0)
absent (0)	present (1)	present (1)	present (1)	absent (0)	absent (0)	absent (0)
asymmetrical (0)	symmetrical (1)	symmetrical (1)	asymmetrical (0)	asymmetrical (0)	asymmetrical (0)	asymmetrical (0)
small (1)	large (0)	large (0)	large (0)	large (0)	large (0)	large (0)
rounded (0)	sharp (1)	sharp (1)	subacute (0)	rounded (0)	subacute (0)	rounded (0)
large (0)	?	?	small (1)	large (0)	large (0)	large (0)
absent (0)	?	?	present (0)	present (0)	present (0)	present (0) (absent in one specimen)
broadly rounded (1 ^a)	?	?	obtuse (1 ^b)	sharp (0)	sharp (0)	sharp (0)
bright (1 ^a)	bright (1 ^a)	bright (1 ^a)	dull yellow (1 ^b)	dark (0)	yellow (1 ^b)	yellow (1 ^b)
Costa Rica	Ecuador	Ecuador	Brasil, Fr. Guiana	<i>Pachylis</i> : Mexico south into Argentina; mostly S. Amer. (O'Shea, 1980)		

de Dios: Rio Rambopata Res., 30 km (air) SW of Pto. Maldonado (290 m), 12°50'S, 69°20'W, 17.II. 1982, R. Wilkerson. Deposited in FSCA.

Diagnosis: This new species is very distinctive: antennals 3 and 4 bicolored, connexival segment 2 entirely pale orange yellow and contrasting with the reddish-brown of segments 3–9.

In *T. heteropus*, antennals 3 and 4 are entirely black, the dilated portion of segment 3 is narrow and elliptical (Fig. 4), and connexival segments 2–9 are dark brown to black. *T. gigas* has antennal 2 entirely black (Fig. 3), but the humeral angles are rounded and obtuse, antennal 4 is black or dark brown and shorter (under 8.25 mm), and connexival segments 2–9 are dark brown to black with scattered yellow spots.

Etymology: Named for the yellow to pale orange yellow connexival segment 2.

PHYLOGENY

Discussion of characters (Table 2)

Characters a–c.—An asymmetrical metatibial dilation (a), a spineless female seventh connexivum (b), and thoracic pleura with very small hirsute patches (c) all occur in the sister genus, *Pachylis*, and are considered plesiomorphic. All *Thasus* have a symmetrical or nearly symmetrical tibial dilation. None has small pleural patches, but some have large ones and others have none. We believe the progression small → large → none to be more likely than small → none → large. A seventh connexivum without a spine occurs in the females of two species of *Thasus* (Table 2); we believe this condition represents independent secondary losses, and therefore treat it as an apomorphy over the presence, which is plesiomorphic within *Thasus* but an autapomorphy of the genus relative to *Pachylis*.

Characters d–i.—The states we consider plesiomorphic occur in all *Pachylis* studied, and in some *Thasus*. Different states in *Thasus*, we consider apomorphic. One character requires further discussion: The tip of the female's second valvula bears a well sclerotized broadly flattened tooth, which is sharply pointed in *Pachylis*. It is either obtuse or broadly rounded in *Thasus* (except in *T. odonnellae*, where it is sharp, a reversal). In *T. neocalifornicus* it is depressed medially, and in *T. gigas* it is asymmetrically bifid. We treat the sharp condition as plesiomorphic, and suggest two pathways therefrom: sharp → broadly rounded (condition 1^a) → slightly or asymmetrically bifid (2); and sharp → obtuse (1^b).

Character j.—The veins of the corium of *Thasus* may be dark (concolorous with the corium itself), bright yellow or orange, or dull yellow (*T. rutilus*). The last two occur also in *Pachylis* and, indeed, in other genera of Nematopodini. The first two conditions occur within *T. acutangulus*, in specimens both dark and light; therefore corial color does not seem correlated with overall darkness of the specimen, as does variation in banding of the legs. Because dark and bright occur intraspecifically, yellow coloration seems not to be intermediate. Therefore we postulate two advanced states, bright (j^a) and yellow (j^b) corial veins, each derived directly from dark veins.

Phylogeny (Fig. 33)

Two clades are apparent. *T. odonnellae* + (*rutilus* + *heteropus*) is characterized by a small dilation of antennal 3 and a small metatrochanteral spine; each of these apomorphies occurs homoplasiouly in the second clade, but not together. In this

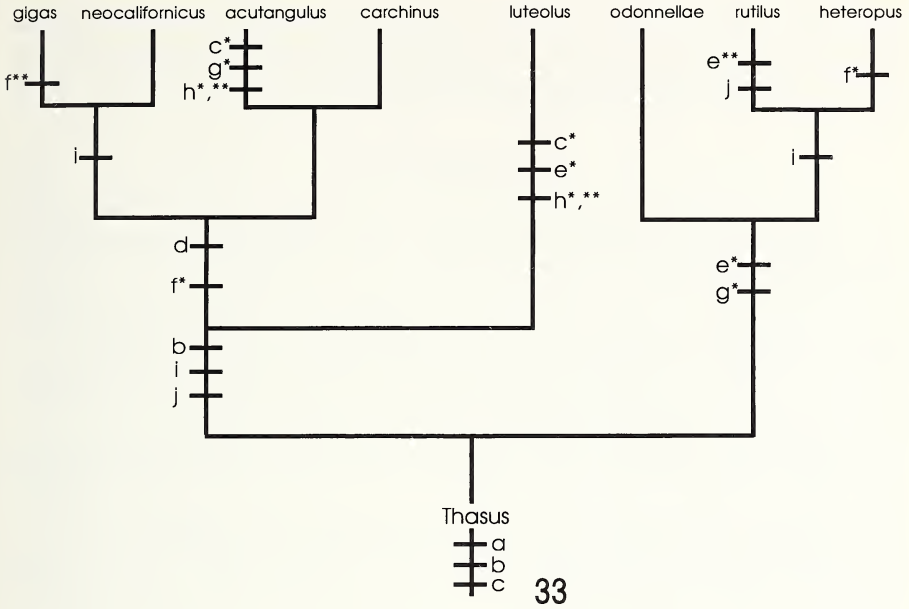

Fig. 33. Cladogram of species of *Thasus*. Most terminal autapomorphies omitted. * = convergence. ** = reversal.

first clade the corial veins are concolorous with the corium itself, except in *T. rutilus*, where they are yellow, but not so bright as in the second clade. Otherwise, these species are uniformly brown (except for the hirsute patches on the pleura).

Members of the second clade (the other five species) have lost the pale hirsute patches on the pleura, their females have a broadly rounded tooth on the second valvula, their corial veins are contrastingly bright, and all but *carchinus* and *acutangulus* have orange or yellow markings on their legs.

Thasus carchinus is suggested here to be the sister genus of *T. acutangulus*. However, we do not know the states of several characters for this species (Table 2), and so its position in the cladogram is unsure. We predict that *T. carchinus* will have a large metatrochanteral spine (character g); but we cannot predict its states of characters h and i.

Finally, the facts that *T. neocalifornicus* has the northernmost distribution of the genus, and is the only *Thasus* (or *Pachylis*, as far as we know) whose antennals 3 and 4 are subequal, suggest to us that this is the most advanced—the most recently arisen—species in the genus.

DISTRIBUTION

The *T. odonnellae* + (*rutilus* + *heteropus*) clade is the southernmost in *Thasus*; and it also shares more features (Fig. 33) with the predominantly South American (O'Shea, 1980) *Pachylis* than do the other *Thasus* species (except *T. luteolus*). The other five *Thasus* species extend from the southwestern United States through Central America; only one is South American, *T. carchinus*, in Ecuador.

The range of the first *Thasus* clade overlaps that of *Pachylis* more than does that of the second clade (*Pachylis* range in O'Shea, 1980), but the distributions of four of the ten *Pachylis* species are unknown; and indeed several *Pachylis* extend into Central America and one (*P. hector* Stål) occurs in México.

ACKNOWLEDGMENTS

We are indebted to the following individuals and institutions for the loan of specimens and other assistance relevant to this study: Dr. Randall T. Schuh (AMNH); Miss Janet Margerison Knight (BMNH); Dr. Norman D. Penny (CAS); Ing. Ernst Heiss (CEH); Drs. J. E. Rawlins and R. L. Davidson (CMP); Dr. R. Hoebeke (CU); Dr. Phil Parrillo (FMNH); Dr. C. L. Hogue (LACM); Dr. Joseph C. Schaffner (TAMU); Dr. John Chemsak (UCB); Dr. Eduardo Osuna (UCV); Dr. Saul Frommer (UCR); Dr. Alvaro Willie (UCCR); Dr. Frank Mead (FSCA); Drs. Richard C. Froeschner (USNM) and Thomas J. Henry (USDA, SEL); and Dr. J. E. O'Donnell (Univ. Conn. Insect Collection). Special thanks to the Consejo Nacional de Ciencia y Tecnología, México (CONACyT) for financial assistance (Project Number 0124-N9106).

We are particularly grateful to Drs. Per Lindskog (Naturhistoriska Riksmuseet, Stockholm) and J. Deckert (Museum für Naturkunde der Humboldt-Universität zu Berlin) for loaning the types of *Thasus acutangulus* and *gigas*, respectively.

We thank Mrs. D. Bassett for typing the paper, rendering form from chaos.

We dedicate this paper to the memory of Dr. Charles L. Hogue (LACM), whom the second author first met some thirty-five years ago.

LITERATURE CITED

- Aldrich, J. R. and M. S. Blum. 1978. Aposematic aggregation of a bug (Hemiptera:Coreidae): the defensive display and formation of aggregations. *Biotropica* 10:58-61.
- Blöte, H. C. 1938. Catalogue of the Coreidae in the Rijksmuseum van Natuurlijke Historie. Part IV. Coreinae, third part. *Zool. Medd., Leiden* 20:275-308.
- Brailovsky, H. 1987. Three new genera and six new species of neotropical Coreidae (Heteroptera). *J. N.Y. Ent. Soc.* 95:518-530.
- Burmeister, H. 1835. *Handbuch der Entomologie Zweiter Band: II Ordnung Rhynchota*. Berlin: Theod. Ehr. Friedr. Enslin I-IV:1-400.
- Dallas, W. S. 1852. List of the specimens of Hemipterous insects in the Collection of the British Museum. Part II. London, Taylor and Francis Inc.: 383-385.
- Distant, W. L. 1881-1892. *Biologia Centrali-Americana. Heteroptera I*. London: 1-462.
- Froeschner, R. C. 1981. Heteroptera or True Bugs of Ecuador: A Partial Catalog. *Smithsonian Contrib. Zool.* 322:1-147.
- Froeschner, R. C. 1988. Family Coreidae Leach 1815. Pages 69-92 *in*: T. J. Henry and R. C. Froeschner (eds.), *Catalog of the Heteroptera, or True Bugs, of Canada and the Continental United States*. E. J. Brill, Leiden.
- Heppner, J. B. and G. Lamas. 1982. Acronyms for world museum collections of insects, with an emphasis on neotropical Lepidoptera. *Bull. Ent. Soc. Amer.* 28:305-315.
- Jones, W. A. 1993. New host and habitat associations for some Arizona Pentatomoidea and Coreidae. *Southwest. Ent. Suppl.* 16:1-29.
- Latreille, P. A. 1811. *Insectes de l'Amerique equinoxiale, recueillis pendant le voyage de MM de Humboldt et Bonpland*: 189-190.
- Lethierry, L. and G. Severin. 1894. *Catalogue general des Hémiptères. Tome II. Hémiptères*. Brussels: F. Hayez. Imprimeur de l'Academie Royale de Belgique: 1-277.
- O'Shea, R. 1980. A generic revision of the Nematopodini (Heteroptera:Coreidae:Coreinae). *Studies Neotrop. Fauna Environ.* 15:197-225.

- Schaefer, C. W. and P. L. Mitchell. 1983. Food plants of the Coreoidea (Hemiptera: Heteroptera). *Ann. Ent. Soc. Am.* 76:591-615.
- Stål, C. 1858. Hemipterologiska bidrag. Öfvers. K. Vet.-Akad. Förh. 15(9-10):433-454.
- Stål, C. 1862. Hemiptera mexicana enumeravit speciesque novas descripsit. *Stett. Ent. Z.* 23: 81-118, 273-281, 289-325, 437-463.
- Stål, C. 1865. Hemiptera nova vel minus cognita. *Ann. Soc. Ent. Fr.* 4:163-188.
- Stål, C. 1867. Bidrag till hemipterernas systematik. Öfvers. K. Vet.-Akad. Förh. 24:491-560.
- Stål, C. 1870. Enumeratio Hemipterorum. I.K. Svenska Vet.-Akad. Hand. 9(1):1-232.
- Torre Bueno, J. R. de la. 1940a. Food-plant of a coreid bug. *Bull. Brooklyn Ent. Soc.* 35:45.
- Torre Bueno, J. R. de la. 1940b. *Thasus gigas* Burmeister, a correction. *Bull. Brooklyn Ent. Soc.* 35:102.
- Torre Bueno, J. R. de la. 1941. A synopsis of the Hemiptera-Heteroptera of America North of Mexico. Part II. Families Coreidae, Alydidae, Corizidae, Neididae, Pyrrhocoridae, and Thaumastotheridae. *Ent. Am. (New Series)* 21:41-122.
- Torre Bueno, J. R. de la. 1942. Note on distribution of Heteroptera. *Bull. Brooklyn Ent. Soc.* 37:183-185.
- Torre Bueno, J. R. de la. 1945. Random notes on *Thasus acutangulus*. *Bull. Brooklyn Ent. Soc.* 40:83.
- Torre Bueno, J. R. de la and W. G. Ambrose. 1936. Effects of the protective vapors of the coreid bug *Thasus gigas* on a tarantula (*Eurypelma* sp.). *Bull. Brooklyn Ent. Soc.* 31:184.
- Uhler, P. R. 1875. Report on the collections of Hemiptera made in portions of Nevada, Utah, California, Colorado, New Mexico and Arizona, during the years 1871, 1873 and 1874. Report upon the United States Geological and Geographical Explorations and Surveys West of the One Hundred Meridian, in Charge of First Lieut. Geo. M. Wheeler, Corps of Engineers, U.S. Army 5:829-842.
- Uhler, P. R. 1876. List of Hemiptera of the Region west of the Mississippi River, including those collected during the Hayden explorations of 1873. *Bull. U.S. Geol. Geog. Surv. Terr.* 1:267-361.
- Uhler, P. R. 1877. Report upon the Hemiptera collected during the years 1874 and 1875, by Mr. P. R. Uhler. *In: G. M. Wheeler, Annual Report upon the Geographical Surveys (West of the One-hundredth Meridian) of the Chief Engineer for 1877. Appendix MN:* 1322-1334.
- Uhler, P. R. 1886. Check list of the Hemiptera Heteroptera of North America. *Bull. Brooklyn Ent. Soc.:* 1-32.
- Uhler, P. R. 1894. Observations upon the heteropterous Hemiptera of Lower California, with description of new species. *Proc. Calif. Acad. Sci.* (2)4:223-295.
- Van Duzee, E. P. 1917. Catalogue of the Hemiptera of America North of Mexico excepting the Aphididae, Coccidae and Aleurodidae. University of California Publ. Tech. Bull. Ent. 2:1-902.
- Van Duzee, E. P. 1923. Expedition of the California Academy of Sciences to the Gulf of California in 1921. The Hemiptera (True Bugs, etc.) *Proc. Calif. Acad. Sci.* (4)12:123-200.
- Walker, F. 1871. Catalogue of the specimens of Hemiptera Heteroptera in the Collection of the British Museum. Part IV. London: 1-211.

Received 7 October 1992; accepted 10 August 1994.